

882 DN 15-65

The new 882 diaphragm valve is particularly suitable for shutting off and regulating abrasive or dirty fluids. The new internal geometry of the body optimises fluid dynamic efficiency by increasing the flow rate and ensuring an optimum linearity of the flow adjustment curve. The 882 is extremely compact and very light. The innovative handwheel is equipped with a patented immediate and ergonomic operating locking device that allows it to be adjusted and locked in any position.

2-WAY DIAPHRAGM VALVE

- Connection system for solvent weld, threaded and flanged joints
- **Optimised fluid dynamic design:** maximum output flow rate thanks to the optimised efficiency of the fluid dynamics that characterise the new internal geometry of the body
- **Internal components in metal, totally isolated from the fluid** and external environment
- **Modularity of the range:** only 2 handwheel and 4 diaphragm and bonnet sizes for 7 different valve sizes
- Non-rising handwheel that stays at the same height during rotation, equipped with a graduated optical indicator protected by a transparent PVC cap with seal O-Ring
- Bonnet fastening screws in AISI 316 steel protected against the external environment by PE plugs. Absence of metal parts exposed to the external environment to prevent any risk of corrosion
- **CDSA** (Circular Diaphragm Sealing Angle) system that, thanks to the uniform distribution of shutter pressure on the diaphragm seal, offers the following advantages:
 - reduction in the tightening torque of the screws fixing the actuator to the valve body
 - reduced mechanical stress on all valve components (actuator, body and diaphragm)
 - easy to clean valve interior
 - low risk of the accumulation of deposits, contamination or damage to the diaphragm due to crystallisation
 - operating torque reduction

Technical specifications	
Construction	Diaphragm valve with maximized flow rate and lockable handwheel
Size range	DN 15 - 65
Diaphragm size	MA 20 - 50
Nominal pressure	PN 10 with water at 20° C
Temperature range	PVC-U: 0 °C - 60 °C - PVC-C: 0 °C - 100 °C PP-H: 0 °C - 100 °C - PVDF: -20 °C - 120 °C ABS: -20 °C - 80 °C
Coupling standards	Solvent welding / Welding: EN ISO 1452, EN ISO 15493, BS 4346-1, DIN 8063, NF T54-028, ASTM D 2467. Can be coupled to pipes according to EN ISO 1452, EN ISO 15493, DIN 8062, NF T54-016, ASTM D 1785 Thread: ISO 228-1, DIN 2999, ASTM D 2464, Flanging system: ISO 7005-1, EN ISO 1452, EN ISO 15493, EN 558-1, DIN 2501, ANSI B16.5 Cl.150, JIS B2220
Reference standards	Construction criteria: EN ISO 16138, EN ISO 1452, EN ISO 15493 Test methods and requirements: ISO 9393 Installation criteria: DVS 2204, DVS 2221, UNI 11242
Valve material	Body: PVC-U / PVC-C / PP-H / PVDF / ABS Bonnet and handwheel: PP-GR Position indicator cap: PVC
Diaphragm material	EPDM, FPM, PTFE (on request NBR)
Control options	Manual control; pneumatic actuator

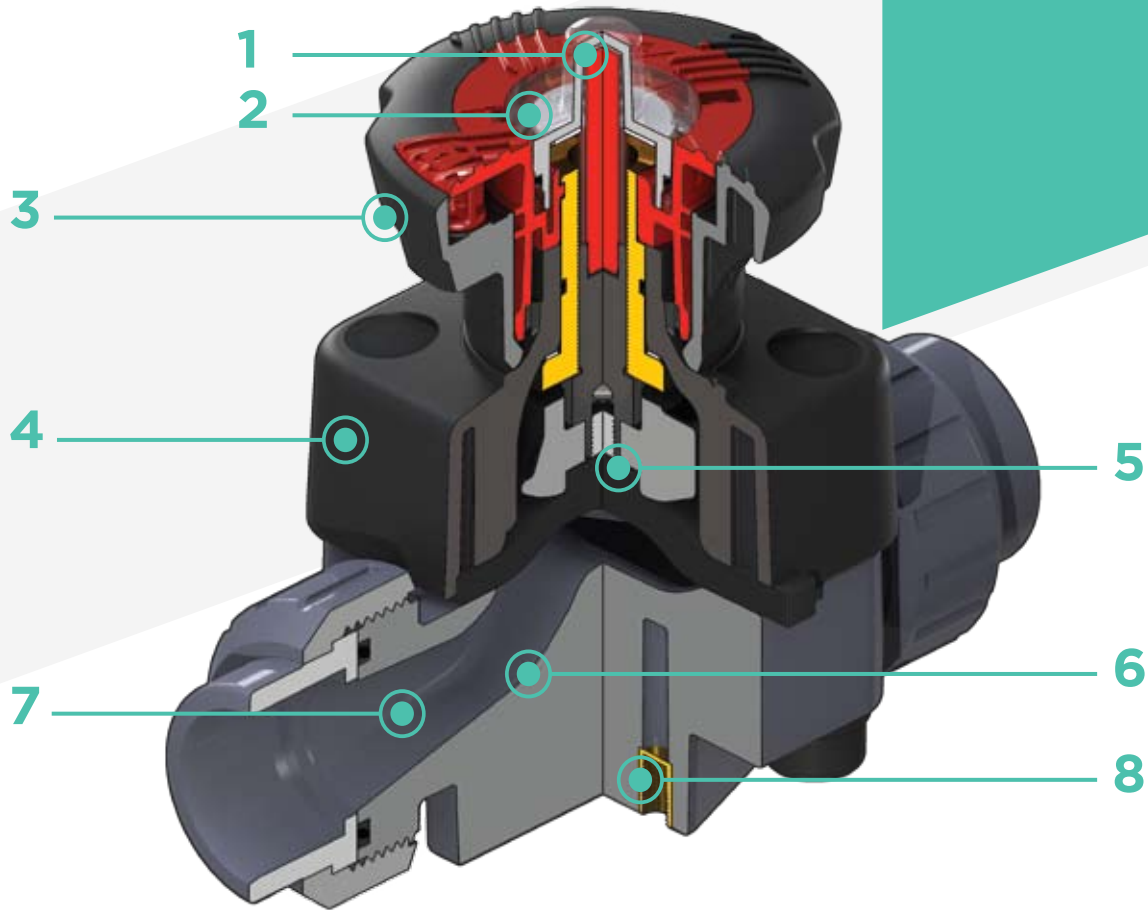

1 High visibility graduated optical position indicator protected by a transparent cap with seal O-Ring

2 Customization plate: the customization lets you identify the valve on the system according to specific needs

3 Locking system: innovative handwheel with a patented immediate and ergonomic operating locking device that allows it **to be adjusted and locked in over 300 positions**

4 Handwheel and bonnet in high mechanical strength and chemically resistant PP-GR, providing full protection by isolating all internal metal parts from contact with external agents

5 Floating pin connection between the control screw and diaphragm to prevent concentrated loads, improve the seal and extend its lifetime

6 New design of valve body interior: substantially increased flow coefficient and reduced pressure drop. The degree of efficiency reached has also enabled **the size and weight** of the valve to be reduced

7 Adjustment linearity: the internal profiles of the valve also greatly improve its characteristic curve, resulting in **extremely sensitive and precise adjustment** along the entire stroke of the shutter

8 Valve anchoring bracket **integrated in the body,** with threaded metal inserts allowing **simple panel or wall mounting** using the wall mounting plate (supplied as an accessory)

TECHNICAL DATA

PRESSURE VARIATION ACCORDING TO TEMPERATURE

For water and harmless fluids to which the material is classified as CHEMICALLY RESISTANT. In other cases, a reduction of the nominal pressure PN is required (25 years with safety factor).

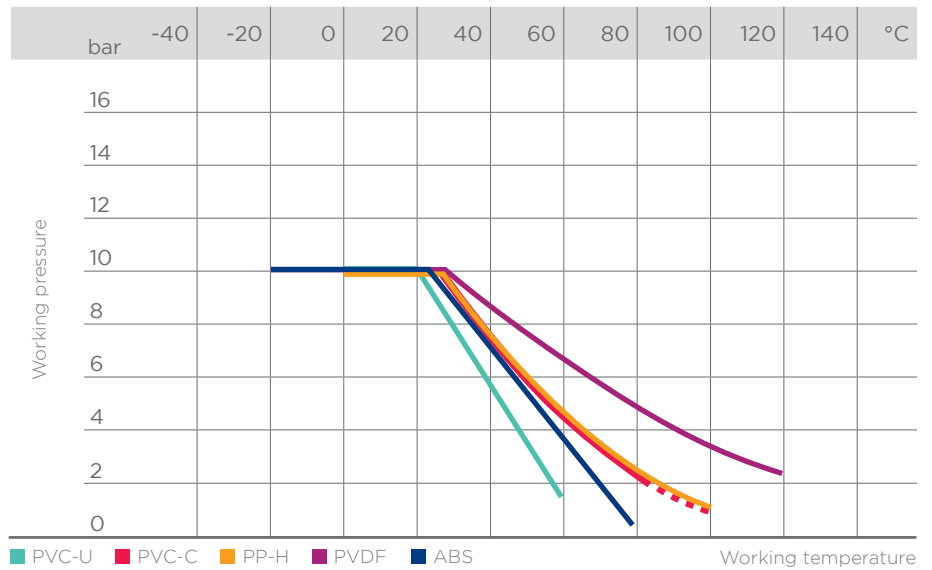

PRESSURE DROP GRAPH

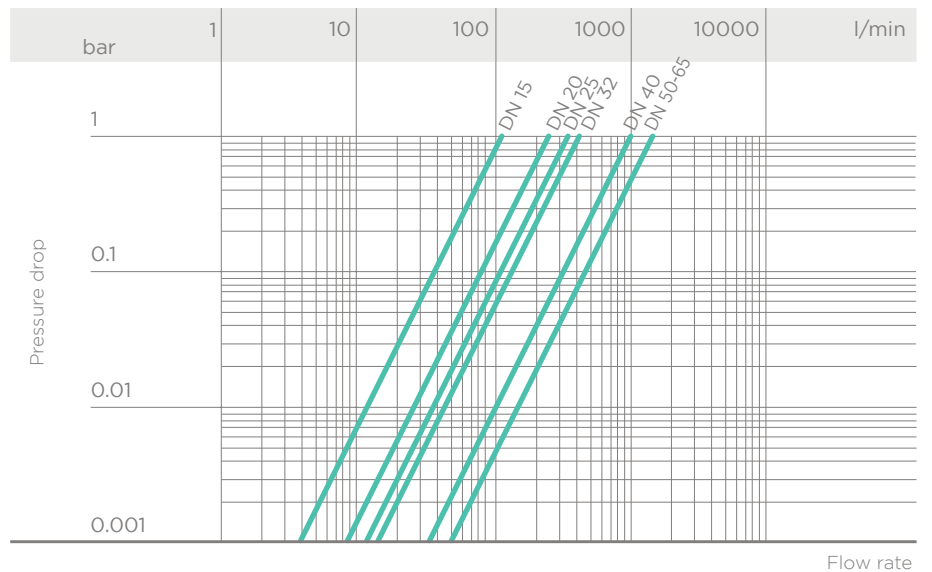

K_v100 FLOW COEFFICIENT

The K_v100 flow coefficient is the Q flow of litres per minute of water at a temperature of 20°C that will generate Δp= 1 bar pressure drop at a certain valve position.

The K_v100 values shown in the table are calculated with the valve completely open.

DN	15	20	25	32	40	50	65
K _v 100 l/min	112	261	445	550	1087	1648	1600

RELATIVE FLOW COEFFICIENT GRAPH

The relative flow coefficient refers to the variation in the flow rate as a function of the valve opening stroke.

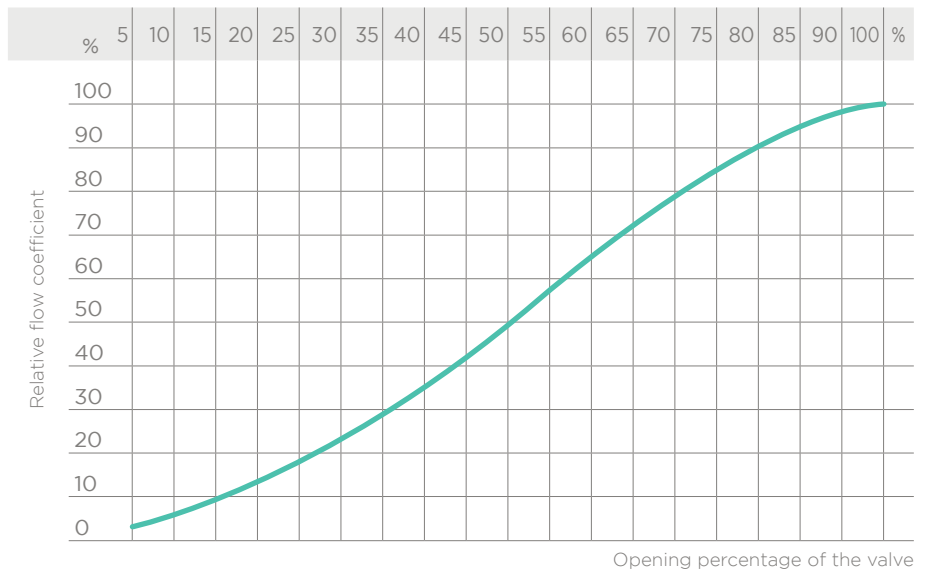

The information in this leaflet is provided in good faith. No liability will be accepted concerning technical data that is not directly covered by recognised international standards. SED reserves the right to carry out any modification. Products must be installed and maintained by qualified personnel.

DIMENSIONS - 882

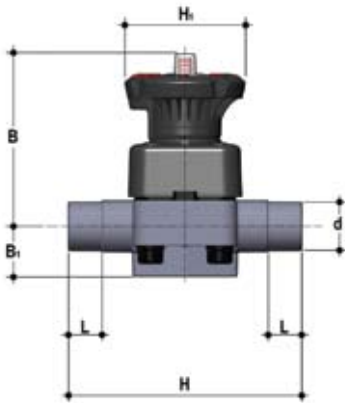

2-way diaphragm valve with **male ends** for solvent respectively socket welding, **metric series**, code 39

DN	MA	PN	B	B ₁	d	H	H ₁	L	Weight (g)		
									PVC-U / PVC-C	PP-H	PVDF
15	20	10	102	25	20	124	80	16	460	430	497
20	20	10	105	30	25	144	80	19	482	445	527
25	25	10	114	33	32	154	80	22	682	620	756
32	25	10	119	30	40	174	80	26	726	650	817
40	40	10	147	35	50	194	120	31	1525	1380	1700
50	50	10	172	46	63	224	120	38	2389	2135	2693
65	50	10	172	46	75	284	120	44	2519	2225	2871

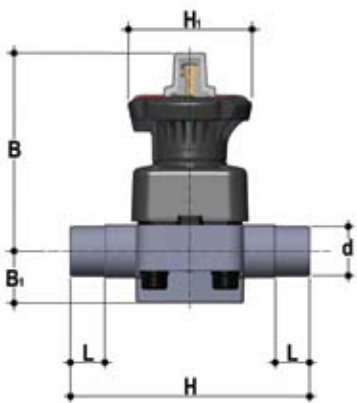

2-way diaphragm valve with **stroke limiter and male ends** for solvent respectively socket welding, **metric series**, code 39

DN	MA	PN	B	B ₁	d	H	H ₁	L	Weight (g)		
									PVC-U / PVC-C	PP-H	PVDF
15	20	10	115	25	20	124	80	16	490	460	527
20	20	10	118	30	25	144	80	19	512	475	557
25	25	10	127	33	32	154	80	22	712	650	786
32	25	10	132	30	40	174	80	26	756	680	847
40	40	10	175	35	50	194	120	31	1585	1440	1760
50	50	10	200	46	63	224	120	38	2449	2195	2753
65	50	10	200	46	75	284	120	44	2579	2285	2931

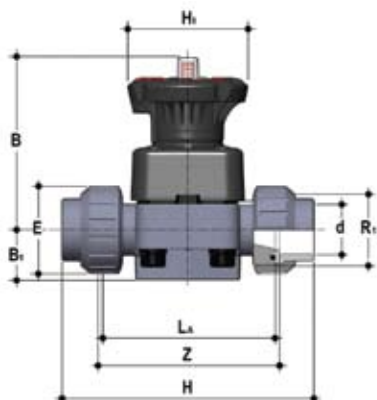

2-way diaphragm valve with **female union ends** for solvent respectively socket welding, **metric series**, code 30

DN	MA	PN	B	B ₁	d	E	H		H ₁	L _A	R ₁	Z		Weight (g)		
							ABS PVC-U PVC-C	PP-H PVDF				ABS PVC-U PVC-C	PP-H PVDF	PVC-U PVC-C	PP-H ABS	PVDF
15	20	10	102	25	20	41	129	128	80	90	1"	100	101	500	457	551
20	20	10	105	30	25	50	154	150	80	108	1" 1/4	116	119	562	500	636
25	25	10	114	33	32	58	168	163	80	116	1" 1/2	124	127	790	695	905
32	25	10	119	30	40	72	192	184	80	134	2"	140	145	916	781	1077
40	40	10	147	35	50	79	222	210	120	154	2" 1/4	160	165	1737	1526	1989
50	50	10	172	46	63	98	266	248	120	184	2" 3/4	190	195	2785	2410	3235

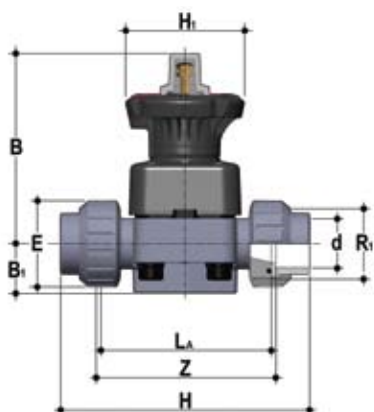

2-way diaphragm valve with **stroke limiter and female union ends** for solvent respectively socket welding, **metric series**, code 30

DN	MA	PN	B	B ₁	d	E	H		H ₁	L _A	R ₁	Z		Weight (g)		
							ABS PVC-U PVC-C	PP-H PVDF				ABS PVC-U PVC-C	PP-H PVDF	PVC-U PVC-C	PP-H ABS	PVDF
15	20	10	115	25	20	41	129	128	80	90	1"	100	101	530	487	581
20	20	10	118	30	25	50	154	150	80	108	1" 1/4	116	119	592	530	666
25	25	10	127	33	32	58	168	163	80	116	1" 1/2	124	127	820	725	935
32	25	10	132	30	40	72	192	184	80	134	2"	140	145	946	811	1107
40	40	10	175	35	50	79	222	210	120	154	2" 1/4	160	165	1797	1586	2049
50	50	10	200	46	63	98	266	248	120	184	2" 3/4	190	195	2845	2470	3295

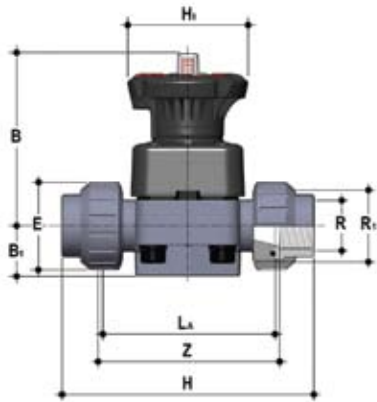

2-way diaphragm valve with **BSP threaded female union ends**, code 33

DN	MA	PN	B	B ₁	E	H	H ₁	L _A	R ₁	Z	Weight (g)	
											PVC-U	PVC-C
15	20	10	102	25	41	131	80	90	1"	97	500	
20	20	10	105	30	50	151	80	108	1" 1/4	118	562	
25	25	10	114	33	58	165	80	116	1" 1/2	127	790	
32	25	10	119	30	72	188	80	134	2"	145	916	
40	40	10	147	35	79	208	120	154	2" 1/4	165	1737	
50	50	10	172	46	98	246	120	184	2" 3/4	195	2785	

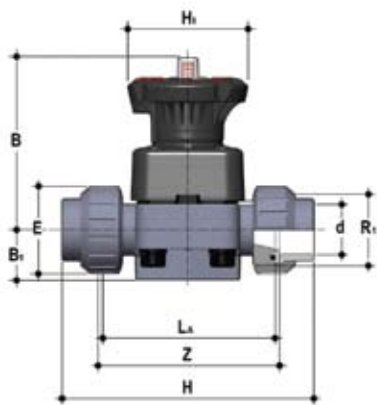

2-way diaphragm valve with **female union ends** for solvent welding, **ASTM series**, code 32

DN	MA	PN	B	B ₁	d	E	H	H ₁	L _A	R ₁	Z	Weight (g)	
												PVC-U	PVC-C
15	20	10	102	25	20	41	143	80	90	1"	98	500	
20	20	10	105	30	25	50	167	80	108	1" 1/4	115	562	
25	25	10	114	33	32	58	180	80	116	1" 1/2	122	790	
32	25	10	119	30	40	72	208	80	134	2	144	916	
40	40	10	147	35	50	79	234	120	154	2" 1/4	164	1737	
50	50	10	172	46	63	98	272	120	184	2" 3/4	195	2785	

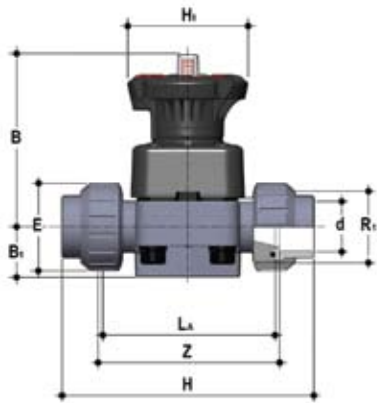

2-way diaphragm valve with **female union ends** for solvent welding, **BS series**, code 31

DN	MA	PN	B	B ₁	E	H	H ₁	L _A	R ₁	Z	Weight (g)	
											PVC-U	PVC-C
15	20	10	102	25	41	131	80	90	1"	97	500	
20	20	10	105	30	50	154	80	108	1" 1/4	116	562	
25	25	10	114	33	58	166	80	116	1" 1/2	121	790	
32	25	10	119	30	72	194	80	134	2"	142	916	
40	40	10	147	35	79	222	120	154	2" 1/4	162	1737	
50	50	10	172	46	98	266	120	184	2" 3/4	194	2785	

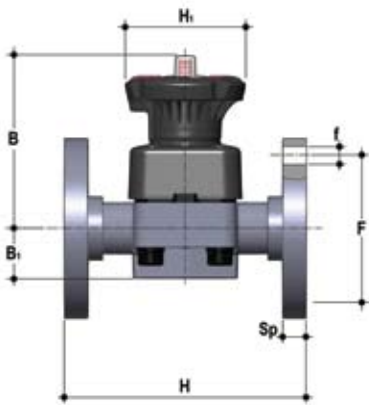

2-way diaphragm valve with **fixed flanges, drilled PN10/16**. Face to face according to EN 558-1, code 81

DN	MA	PN	B	B ₁	f	F	H	H ₁	Sp	U	Weight (g)		
											PVC-U	PVC-C	PP-H
15	20	10	102	25	14	65	130	80	13.5	4	690	588	810
20	20	10	105	30	14	75	150	80	13.5	4	682	645	862
25	25	10	114	33	14	85	160	80	14	4	972	910	1141
32	25	10	119	30	18	100	180	80	14	4	1186	1110	1532
40	40	10	147	35	18	110	200	120	16	4	2100	1955	2481
50	50	10	172	46	18	125	230	120	16	4	3159	2905	3690
65	50	10	225	55	18	145	290	120	21	4	3619	3325	4263

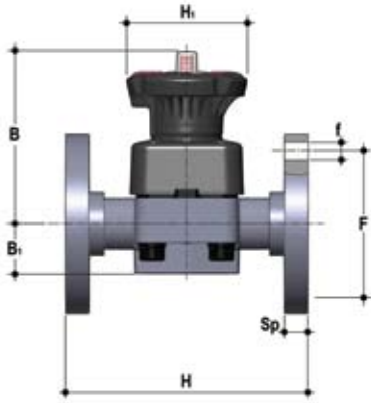

2-way diaphragm valve with **fixed flanges, drilled ANSI B16.5 cl. 150 #FF**, code 88

DN	MA	PN	B	B ₁	f	F	H	H ₁	Sp	U	Weight (g)		
											PVC-U PVC-C	PP-H	PVDF
15	20	10	102	25	14	60.3	108	80	13.5	4	667	572	810
20	20	10	105	30	15.7	69.9	150	80	13.5	4	682	645	862
25	25	10	114	33	15.7	79.4	160	80	14	4	972	910	1141
32	25	10	119	30	15.7	88.9	180	80	14	4	1186	1110	1532
40	40	10	147	35	15.7	98.4	200	120	16	4	2100	1955	2481
50	50	10	172	46	19	120.7	230	120	16	4	3159	2905	3690
65	50	10	172	46	19	139.7	290	120	21	4	3619	3325	4263

ACCESSORIES

Long spigot PE100 end connectors for electrofusion or butt welding, code 36



DN	L	H	SDR		
			PVC-U	PVC-C	PP-H
15	95	280	11	11	11
20	95	298	11	11	11
25	95	306	11	11	11
32	95	324	11	11	11
40	95	344	11	11	11
50	95	374	11	11	11

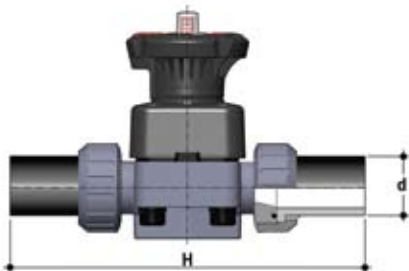

Long spigot PP-H, code 35 and **PVDF** code 30 - S1209 end connectors for butt welding

DN	L	H	SDR	
			PP-H	PVDF
15	95	280	11	21
20	95	298	11	21
25	95	306	11	21
32	95	324	11	21
40	95	344	11	21
50	95	374	11	21

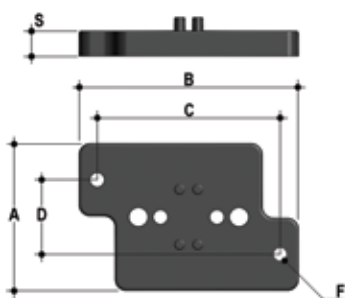

Wall mounting plate PVC-U

DN	A	B	C	D	F	S
15	65	97	81	33	5.5	11
20	65	97	81	33	5.5	11
25	65	97	81	33	5.5	11
32	65	97	81	33	5.5	11
40	65	144	130	33	6.5	11
50	65	144	130	33	6.5	11
65	65	144	130	33	6.5	11

FASTENING AND SUPPORTING



All valves, whether manual or actuated, must be adequately supported in many applications.

The 882 valve series is therefore provided with an integrated bracket that permits direct anchoring of the valve body without the need of other components.

For wall installation, dedicated wall mounting plates which are available as accessories can be used. These plates should be fastened to the valve before wall installation.

The wall plate also allows the 882 valve to be aligned with SED pipe clips.

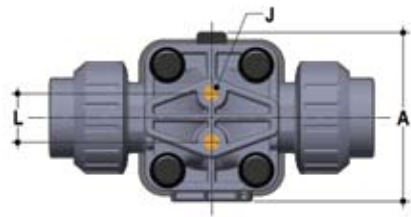

d	DN	A	L	J
20	15	74	25	M6 x 10
25	20	74	25	M6 x 10
32	25	87	25	M6 x 10
40	32	87	25	M6 x 10
50	40	114	44.5	M8 x 14
63	50	136	44.5	M8 x 14
75	65	136	44.5	M8 x 14

CUSTOMIZATION

The 882 DN 15-65 valve can be customised using a customization plate in white PVC.

The customization plate (B), housed in the transparent protection cap (A), can be removed and, once overturned, used for indicating identification serial numbers or service indications on the valves such as, for example, the valve function in the system, the conveyed fluid, but also specific information for customer service, such as the customer name or installation date or location on the valves. The waterproof transparent protection cap with seal O-Ring protect the customization plate against deterioration.

To access the customization plate, make sure that the handwheel is in the release position and proceed as follows:

- 1) Rotate the transparent protection cap fully anticlockwise (fig. 1) and remove it by pulling upwards. If necessary, insert a screwdriver in slot (C) to make the operation easier (fig. 2).
- 2) Remove the plate from inside the transparent protection cap and customise as required (fig. 3).
- 3) Re-assemble everything making sure that the transparent protection cap O-Ring remains in its seating (fig. 4).

Fig. 1



Fig. 2



Fig. 3

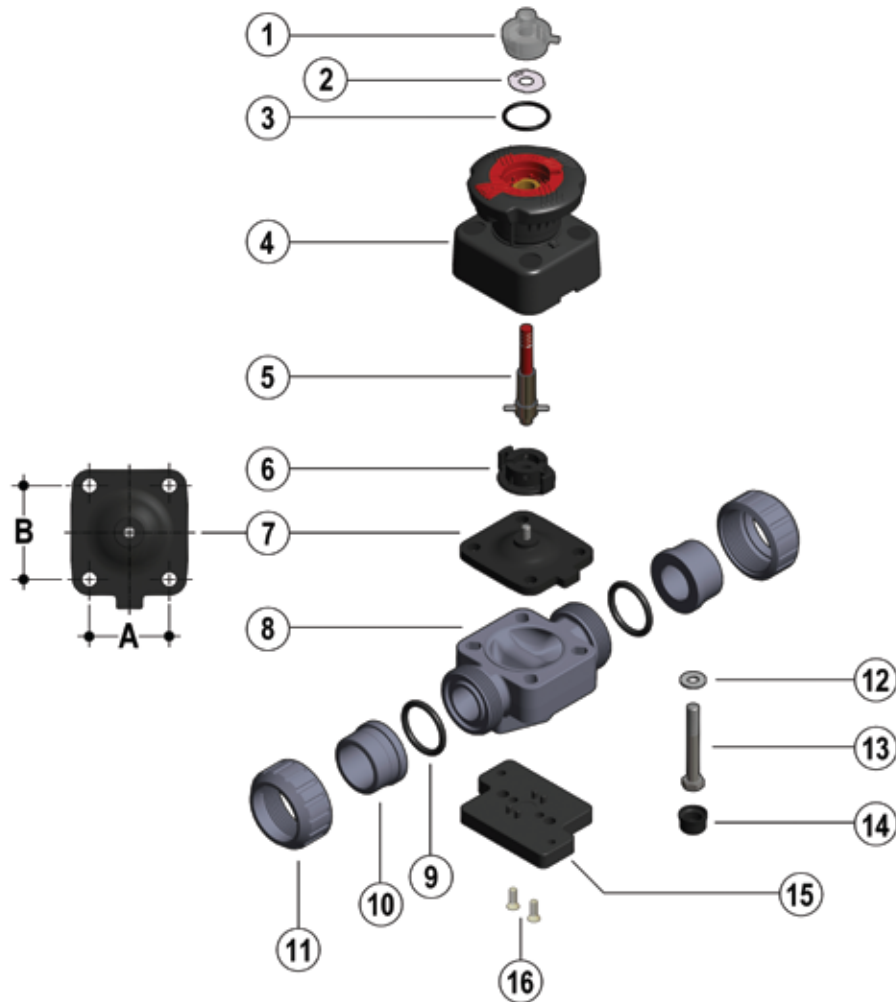

Fig. 4



COMPONENTS

EXPLODED VIEW DN 15-50



DN	15	20	25	32	40	50	65
A	40	40	46	46	65	78	78
B	44	44	54	54	70	82	82

- 1 · Transparent protection cap (PVC - 1)*
- 2 · Customization plate (PVC - 1)
- 3 · O-Ring (EPDM - 1)
- 4 · Operating mechanism (PP-GR / PVDF - 1)
- 5 · Threaded stem - Indicator (Stainless steel - 1)

- 6 · Compressor (IXEF - 1)
- 7 · Diaphragm seal (EPDM, FPM, PTFE - 1)*
- 8 · Valve body (PVC-U - 1)*
- 9 · Socket seal O-ring (EPDM-FPM - 2)*
- 10 · End connector (PVC-U - 2)*
- 11 · Union nut (PVC-U - 2)*

- 12 · Washer (Stainless steel - 4)
- 13 · Bolt (Stainless steel - 4)
- 14 · Protection plug (PE - 4)
- 15 · Distance plate (PP-GR - 1)**
- 16 · Screw (Stainless steel - 2)**

* Spare parts

** Accessories

The material of the component and the quantity supplied are indicated between brackets

DISASSEMBLY

- 1) Isolate the valve from the line (release the pressure and empty the pipeline).
- 2) If necessary, release the handwheel by pressing downwards (fig.5) and rotating anticlockwise to fully open the valve.
- 3) Unscrew the union nuts (11) and extract the valve sideways.
- 4) Remove the protection plugs (14) and bolts (13) with the relative washers (12).
- 5) Separate the valve body (8) from the internal components (4).
- 6) Rotate the handwheel clockwise to free the threaded stem (5), compressor (6) and diaphragm (7)
- 7) Unscrew the diaphragm (7) and remove the shutter (6).

ASSEMBLY

- 1) Insert the compressor (6) on the threaded stem (5) aligning it correctly with the reference pin on the stem.
- 2) Screw the diaphragm (7) on the threaded stem (5).
- 3) Lubricate the threaded stem (5), insert it in the operating mechanism (4) and rotate the handwheel anticlockwise until the stem is fully screwed in (5). Make sure that the compressor (6) and diaphragm are correctly aligned with the housings in the operating mechanism (4) (fig. 7).
- 4) Fit the operating mechanism (4) on the valve body (8) and tighten the bolts (13) with the relative washers (12).
- 5) Tighten the bolts (13) evenly (diagonally) to the tightening torque suggested on the relative instruction sheet.
- 6) Replace the protection plugs (14)
- 7) Position the valve body between the end connectors (10) and tighten the union nuts (11), making sure that the socket seal O-rings (9) do not exit their seats.
- 8) If necessary, block the handwheel by grasping it and pulling it upwards (fig. 6).



Note: during assembly, it is advisable to lubricate the threaded stem. Mineral oils are not recommended for this task as they react aggressively with EPDM rubber.

Fig. 5



Fig. 6



Fig. 7

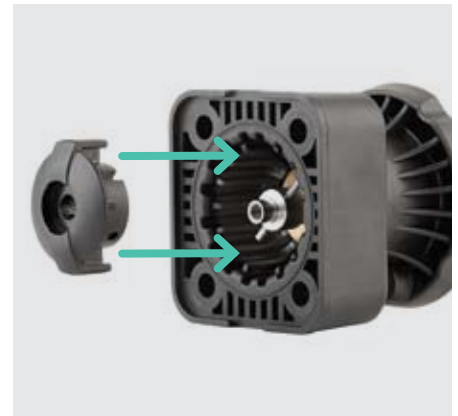

INSTALLATION

Before proceeding with installation, please follow these instructions carefully: (these instructions refer to union end versions). The valve can be installed in any position and in any direction.

- 1) Check that the pipes to be connected to the valve are aligned in order to avoid mechanical stress on the threaded joints.
- 2) Unscrew the union nuts (11) and insert them on the pipe segments.
- 3) Solvent weld or screw the end connectors (10) onto the pipe ends.
- 4) Position the valve body between the end connectors, making sure that the socket seal O-rings (9) do not exit their seats.
- 5) Fully tighten the union nuts (11).
- 6) If necessary, support the pipework with SED pipe clips or by means of the carrier built into the valve itself (see paragraph "Fastening and supporting").

 **Note:** Before putting the valve into service, check that the bolts on the valve body (13) are tightened correctly at the suggested torque.

Fig. 9



ADJUSTMENT

LOCKING DEVICE



The 882 valve is equipped with a handwheel locking system that prevents the valve from being operated. The system can be engaged by simply lifting the handwheel once the required position has been reached (fig. 8). To release the operating mechanism, simply return the handwheel to its previous position by pushing it downwards (fig. 6). When the system is in the locked position, a lock can be installed to protect the plant against unwanted interference (fig. 9).

STROKE LIMITER

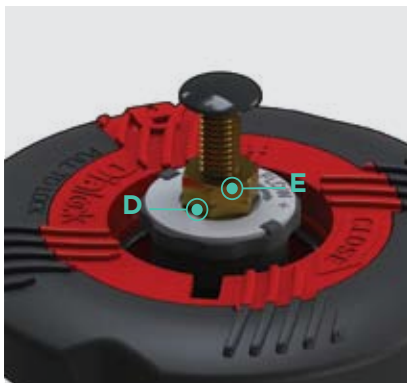

The version of the diaphragm valve equipped with a handwheel stroke control system allows the minimum and maximum flows to be preset. The system allows the valve stroke to be modified using the two independent adjusting screws, which determine the mechanical limits of the valve during opening and closing. The valve is sold with the stroke limiters positioned such that does not limit the opening or closing stroke. To access and set the adjusting screws, remove the transparent protection cap (A) as previously described (see chapter “Customization”).

Travel stop adjustment. Minimum flow rate

- 1) Rotate the handwheel clockwise until the required minimum flow rate is reached.
- 2) Screw in nut (D) as far as it will go and lock it in this position by tightening the lock-nut (E).
If it is not necessary to limit the closing stroke, completely unscrew nuts (D and E). In this way, the valve will fully close.
- 3) Re-assemble the transparent protection cap making sure that the seal O-Ring remains in its seating.



Stroke limiter adjustment. Maximum flow rate

- 1) Rotate the handwheel anticlockwise until the required maximum flow rate is reached.
- 2) Rotate knob (F) anticlockwise as far as the stop. The plate indicates the direction of rotation of the wheel required to obtain a higher or lower maximum flow rate. If the opening stroke does not need to be limited, rotate the knob (F) clockwise a number of times. In this way, the valve will fully open.
- 3) Re-assemble the transparent protection cap making sure that the seal O-Ring remains in its seating.