

Installation, Maintenance and Operating Manual

VALVE CONTROL LTD
ELECTRIC & PNEUMATIC ACTUATORS + VALVE PACKAGES

9 Brookside Industrial Estate, Sawtry,
Huntingdon, Cambridgeshire. PE28 5SB

Tel: +44 (0) 1487 833080
Fax: +44 (0) 1487 833081
Email: sales@valvecontrol.co.uk



LUF Series Unidirectional Electric Actuators

Table of Contents

- 1 General 2
 - 1.1 Description 2
 - 1.2 Parts List..... 2
 - 1.3 General Technical Information 2
- 2 TEMPERATURE LIMITS 2
 - 2.1 Low ambient temperatures: 2
 - 2.2 High ambient temperatures: 2
 - 2.3 High media temperatures: 2
- 3 Mounting the Actuator..... 2
 - 3.1 Actuator Drive Output Requirements: 2
 - 3.2 Bracket requirements: 2
- 4 Wiring 5
- 5 Adjustment of the Limit Switches..... 5
 - 5.1 Adjust the OPEN, (0° and 180°) limit switch cam 5
 - 5.2 Adjust the CLOSED, (90° and 2700°) limit switch cam 5
- 6 Other Options 5

READ THESE INSTRUCTIONS FIRST!
This instruction manual contains important information regarding the installation, operation and troubleshooting of Valve Control Limited's LUF-Series Electric Actuators. Please read these instructions carefully and save them for future reference.

1 General

1.1 Description

Valve Control Limited's LUF-Series Electric Actuators are designed to provide reliable and efficient operation of 1/4-turn ball valves or other types of valves, which allow for 360 degrees of rotation with 90 degree stops.

The supported torque range for actuation is between 150 and 600 inch pounds. LUF-Series actuators are available in AC models with a 25% duty cycle and DC models with an 80% duty cycle.

1.2 Parts List

1. Limit Switches
2. Cams
3. O-Ring

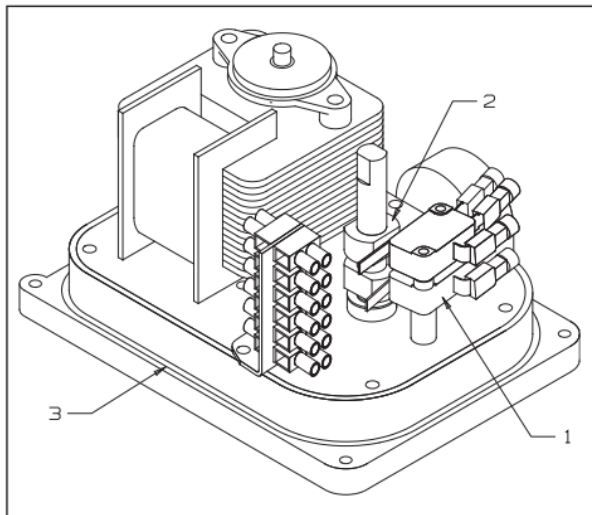

Figure 1 Parts Identification

1.3 General Technical Information

LUF-Series AC voltage actuators have a shaded-pole motor. LUF-Series DC voltage actuators have a brushed DC motor.

It is important to verify that the output torque of the actuator is appropriate for the torque requirements of the valve and that the actuator duty cycle is appropriate for the intended application.

2 TEMPERATURE LIMITS

2.1 Low ambient temperatures:

The minimum recommended ambient temperature without the optional heater and thermostat is approximately 30°F (although it varies with the frequency of use).

With the optional heater and thermostat installed, the recommended minimum ambient temperature is -40°F.

2.2 High ambient temperatures:

The maximum recommended ambient temperature is 150°F.

2.3 High media temperatures:

For media temperatures up to 200°F, additional precautions are not typically required. For media temperatures between 200°F and 300°F, a shielding plate about one inch larger than the actuator in each dimension should be placed between the actuator and the mounting bracket.

In addition, the actuator should be mounted at the 3 o'clock or 9 o'clock position relative to the pipe. For media temperatures above 300°F, a valve with an extended shaft mounting arrangement should be used.

CAUTION:

Dangerous voltages are present inside the actuator cover unless the power supply to the actuator has been shut off or disconnected.

Use extreme caution whenever working on the actuator with the cover removed.

3 Mounting the Actuator

First verify that the output torque of the actuator is appropriate for the torque requirements of the valve and that the actuator duty cycle is appropriate for the intended application.

3.1 Actuator Drive Output Requirements:

Valve Control Limited's LUF-Series actuators have a square output drive. ISO 5211 bolt circle configurations are provided (see Figures 2A and 2B).

3.2 Bracket requirements:

It is mandatory that the actuator be firmly secured to a sturdy mounting bracket. A minimum of four bolts with lock washers must be used to secure the actuator to the bracket.

There can be no flexibility in the bracket, and backlash ("play") in the coupling should be minimized. In addition, the actuator output shaft must be in line (centred) with the valve shaft. This avoids side-loading the shafts (crossed-slot couplings are more tolerant of misalignment).

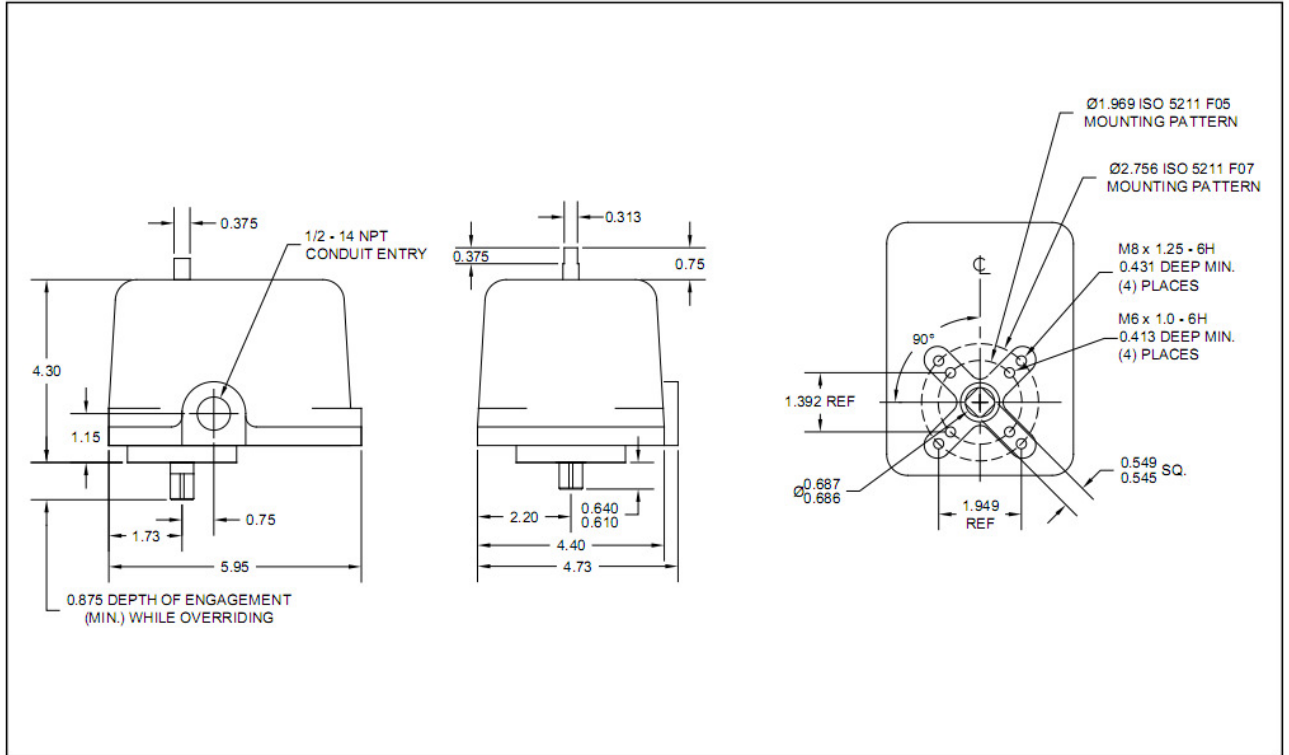

Figure 2A Dimensions, Male output (standard)

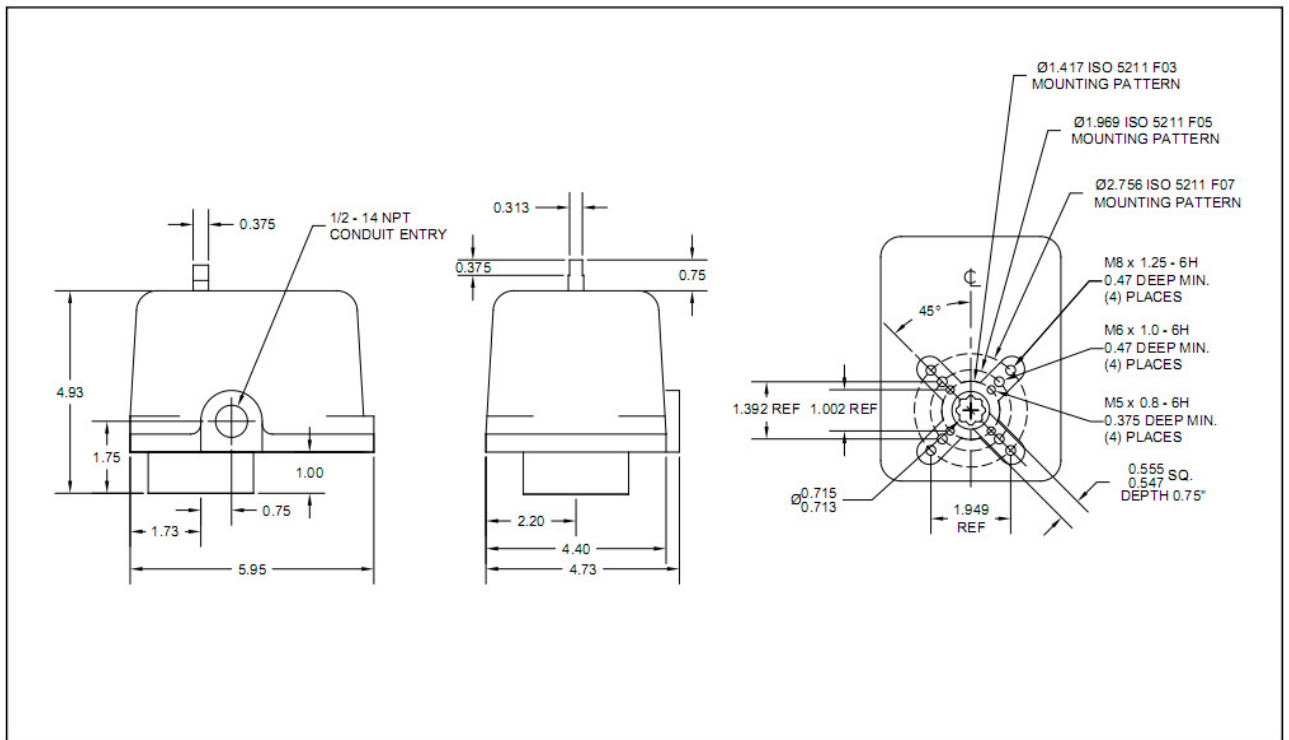

Figure 2B Dimensions, Female output (optional)

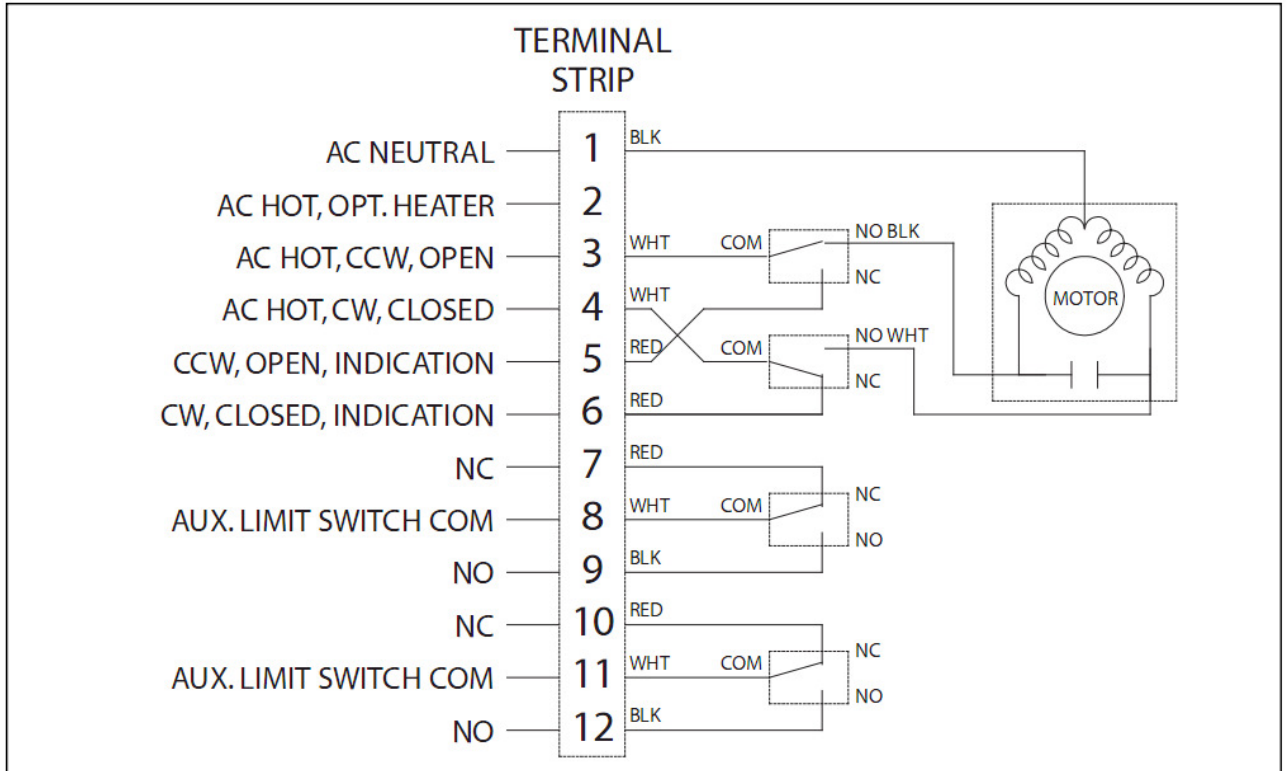

Figure 3A LUF Series AC Wiring

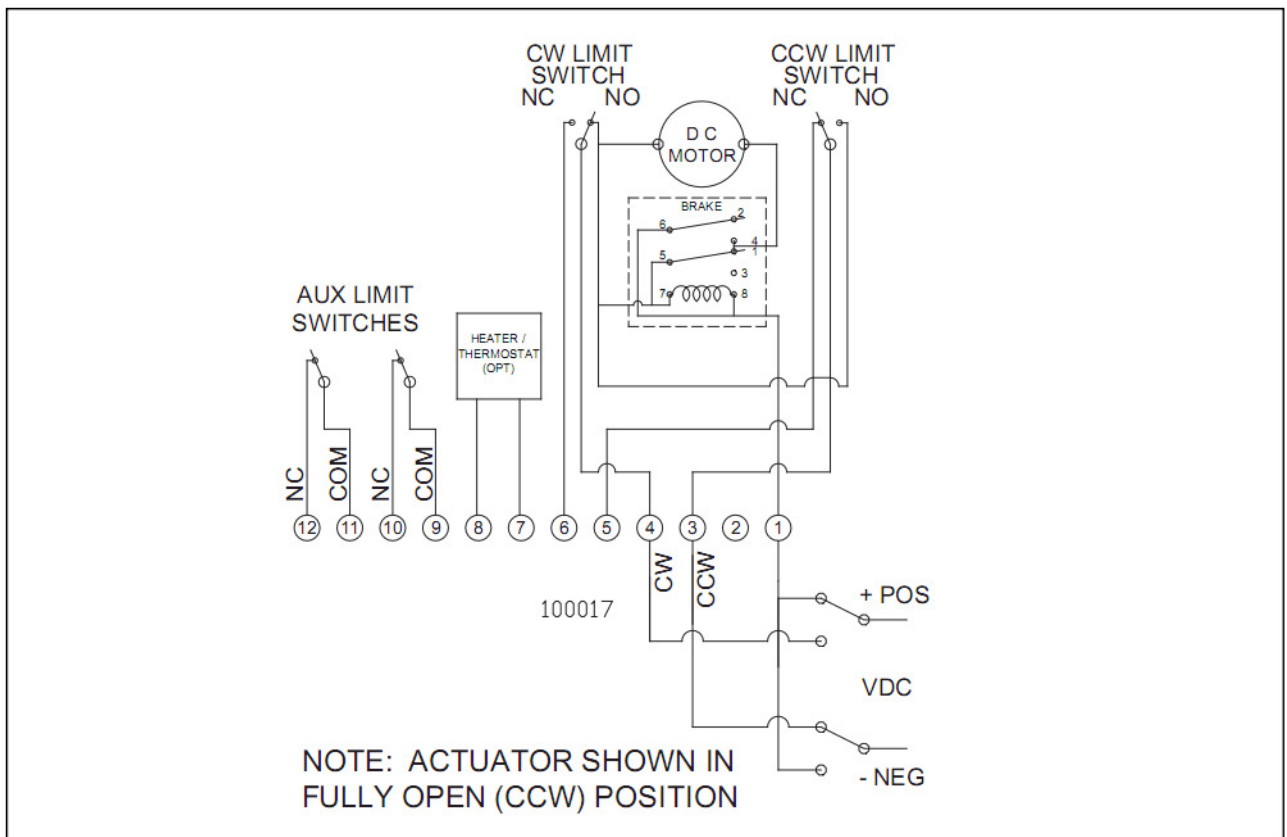

Figure 3B LUF Series DC Wiring

4 Wiring

Note: Be sure to follow local wiring codes.

The identification label on each actuator specifies the voltage and current requirements for the actuator. Figure 3 shows the standard power and control wiring connections for AC and DC actuators.

To operate the LUF-Series actuator, the user supplies power to the actuator's motor through two limit switches. The limit switches control the actuator's mechanical travel limits and are factory set at 90 degrees.

The identification label on each actuator specifies the voltage and current requirements for the actuator. For convenience, Figures 3A and 3B show the standard power and control wiring connections for the actuator. The terminal strip is numbered from the bottom to the top.

Since all LUF-Series actuators travel in the clockwise direction in 90° increments, applying power between terminals 1 and 4 will stop the actuator at the 90° or 270° positions (closed); applying power between terminals 1 and 3 will stop the actuator at the 0° or 180° positions (open).

NOTE: LUF-Series actuators have a 25% duty cycle, which means that for every operating cycle that the actuator is ON (to open or close the valve); the actuator must be OFF for a time equal to three operating cycles.

For example, if the operating cycle time is 5 seconds, for every operating cycle that the actuator is ON, it must be OFF for 15 seconds. Exceeding the actuator's duty cycle may cause the thermal overload switch to temporarily shut off power to the motor.

5 Adjustment of the Limit Switches

If adjustment of the open or closed position is required, proceed as follows:

5.1 Adjust the OPEN, (0° and 180°) limit switch cam

- 1 Using a hex wrench, loosen the set screw in the OPEN limit switch cam (the second up from the bottom).
- 2 Apply power to terminals 1 and 3 (See Figures 3A and 3B) to drive the actuator to the open position (clockwise rotation).
- 3 Remove the power from the actuator.
- 4 Rotate the cam toward the limit switch arm just until the switch clicks closed.
- 5 Set the vertical cam position so that the bottom of the cam will be in contact with the limit switch arm.
Tighten the Cam set screw to secure the Cam in position. Do not over-tighten the screws (use less than 8 in/lbs of tightening torque).

5.2 Adjust the CLOSED, (90° and 270°) limit switch cam

- 1 Using a hex wrench, loosen the set screw in the CLOSED limit switch cam (the bottom one).
- 2 Apply power to terminals 1 and 4 (See Figures 3A and 3B) to drive the actuator to the closed position (clockwise rotation).
- 3 Remove the power from the actuator.
- 4 Rotate the cam toward the limit switch arm just until the switch clicks closed.
- 5 Set the vertical cam position so that the bottom of the cam will be in contact with the limit switch arm.
Tighten the Cam set screw to secure the Cam in position. Do not over-tighten the screws (use less than 8 in/lbs of tightening torque).

6 Other Options

Other options such as extra limit switches and heater/thermostats are available. For further details please consult Valve Control Limited.